

Psykoedukativ Profil

TEACCH Individualiserade Psykoedukativa
Bedömning för Barn med Autismspektrumtillstånd

Tredje versionen

Bilderbok

Eric Schopler

Margaret D. Lansing

Robert J. Reichler

Lee M. Marcus

PRO-ED

8700 Shoal Creek Boulevard Austin, Texas 78757-6897

800/897-3202 Fax 800/397-7633 www.proedinc.com

© 2005 by PRO-ED, Inc.
8700 Shoal Creek Boulevard
Austin, Texas 78757-6897
800/897-3202 Fax 800/397-7633
www.proedinc.com

All rights reserved. No part of the material protected by this copyright notice may be reproduced or used in any form or by any means, electronic or mechanical, including photocopying, recording, or by any information storage and retrieval system, without prior written permission of the copyright owner.

Translated from *PEP-3: Psychoeducational Profile- Third Edition*,
by E. Schopler, M. Lansing, R. Reichler, and L. Marcus, 2005,
Austin, TX: PRO-ED, Inc.

© Copyright 2005 by PRO-ED, Inc. Translated with Permission.

Översatt från *PEP-3: Psychoeducational Profile- Third Edition*,
av E. Schopler, M. Lansing, R. Reichler, and L. Marcus, 2005,
Austin, TX: PRO-ED, Inc.

© Copyright 2005 by PRO-ED, Inc. Översatt med tillstånd.

Översättning: Pedagogiskt Perspektiv AB.

39. Matchar 5 föremål med bild.
A. blyertspenna

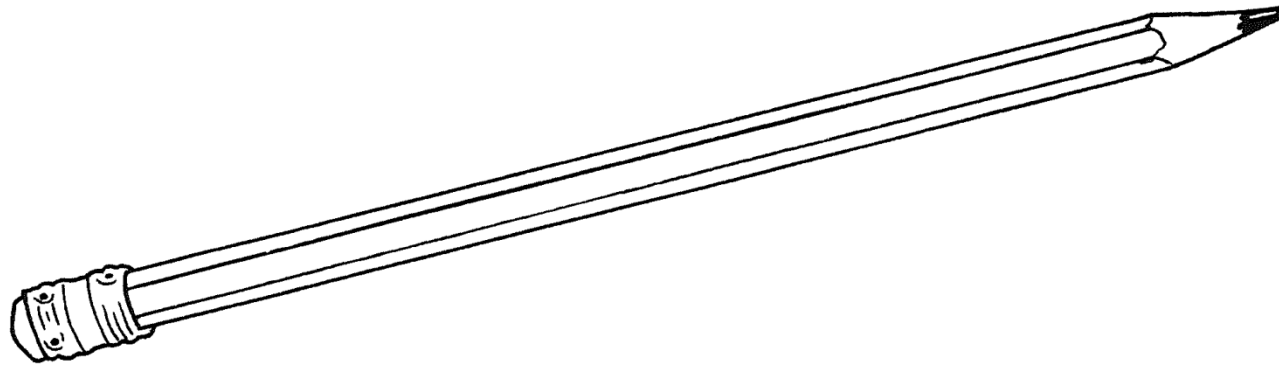

39B. glas

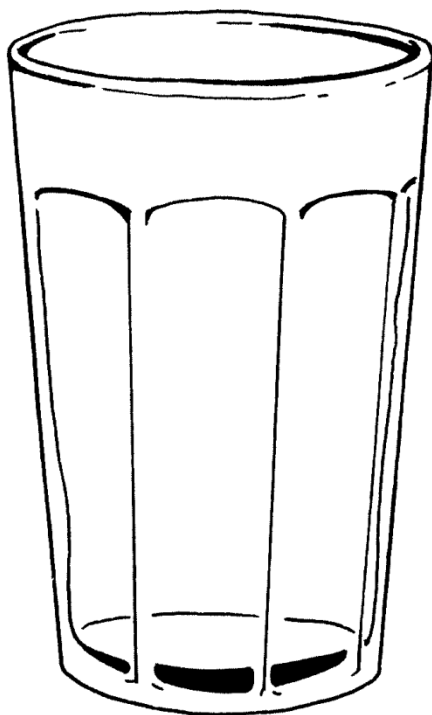

39C. kam

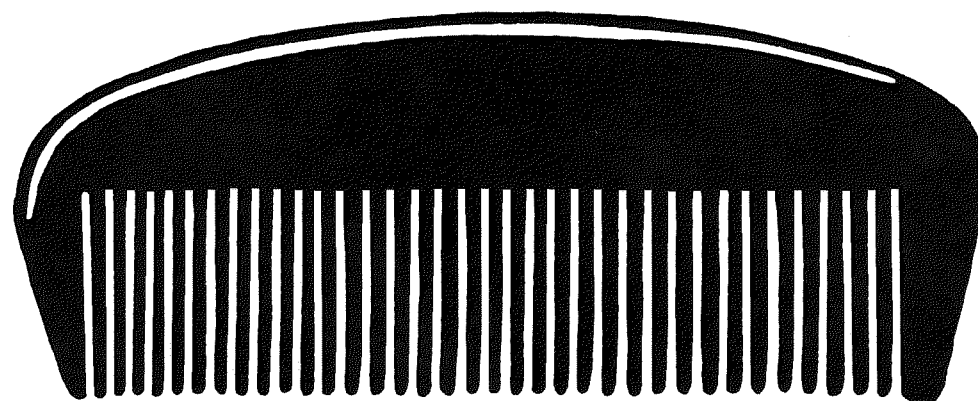

39D. tandborste

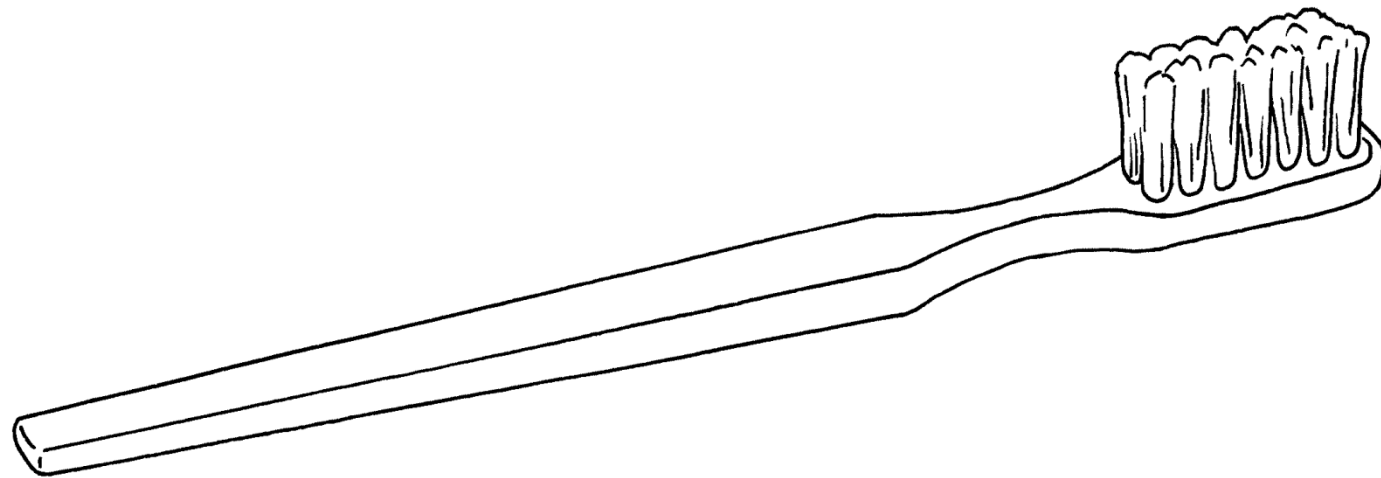

39E. sked

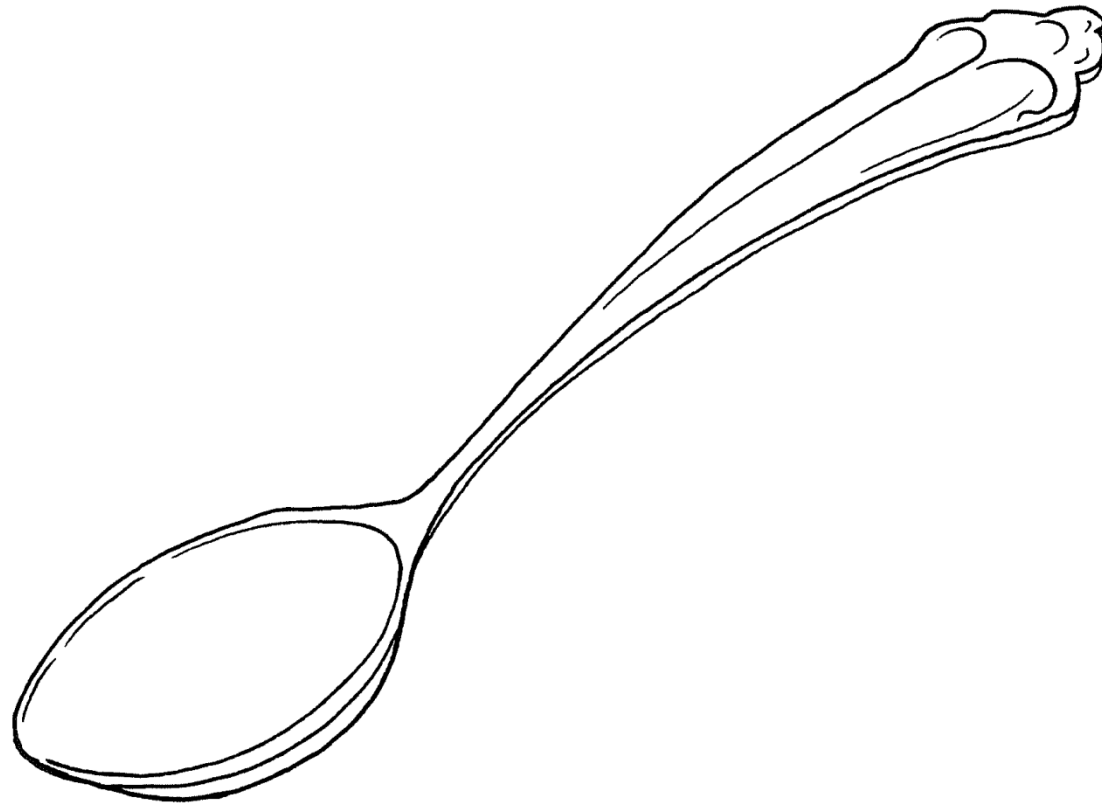

39F. sax

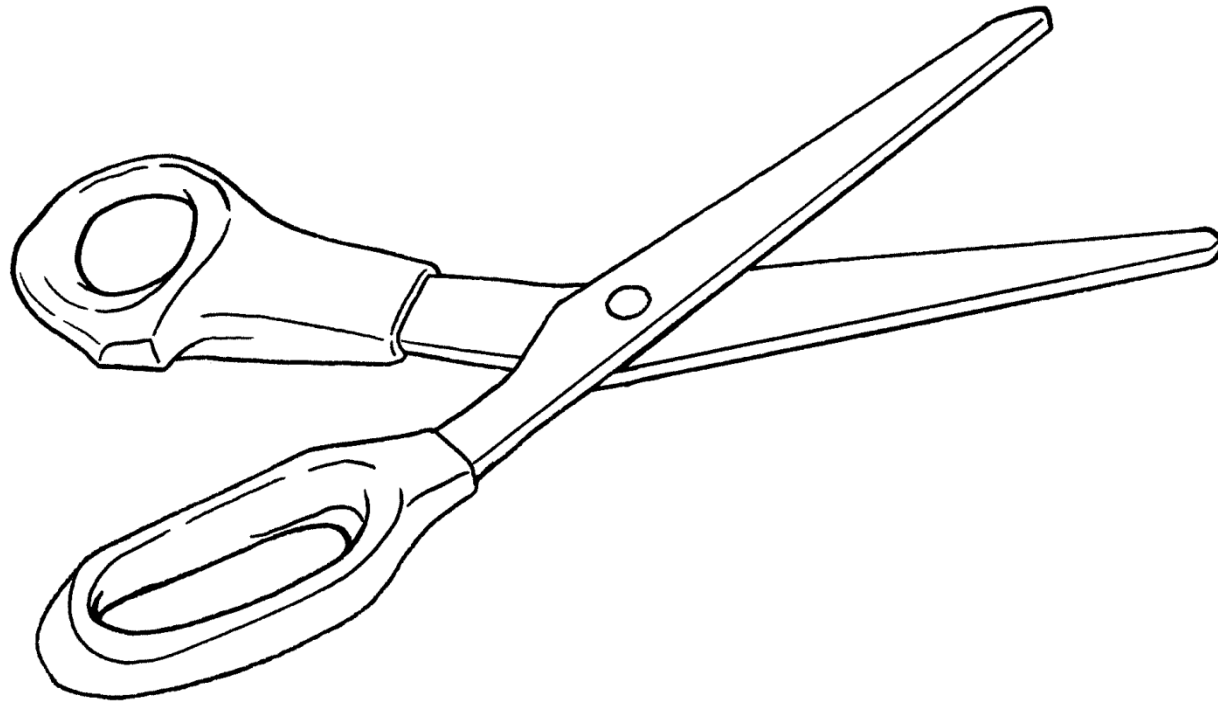

39G. strumpa

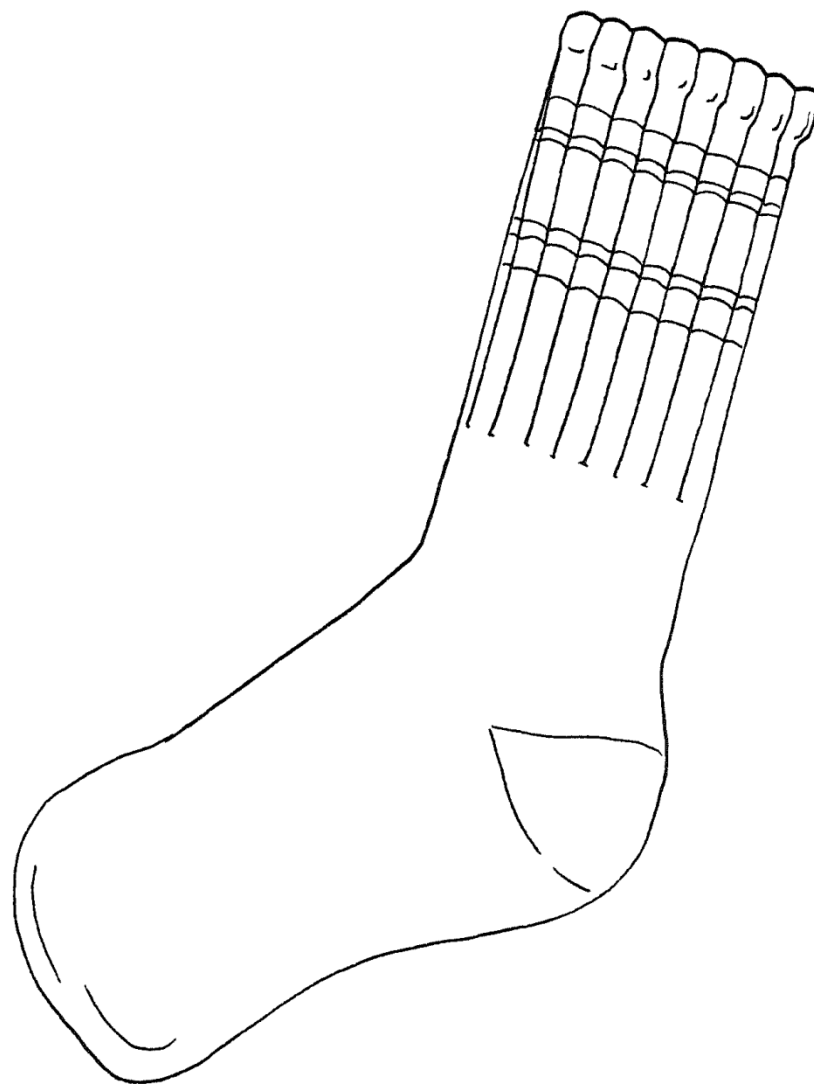

84. Åskådliggör hur 5 föremål på bild används på adekvat sätt.
A. såg

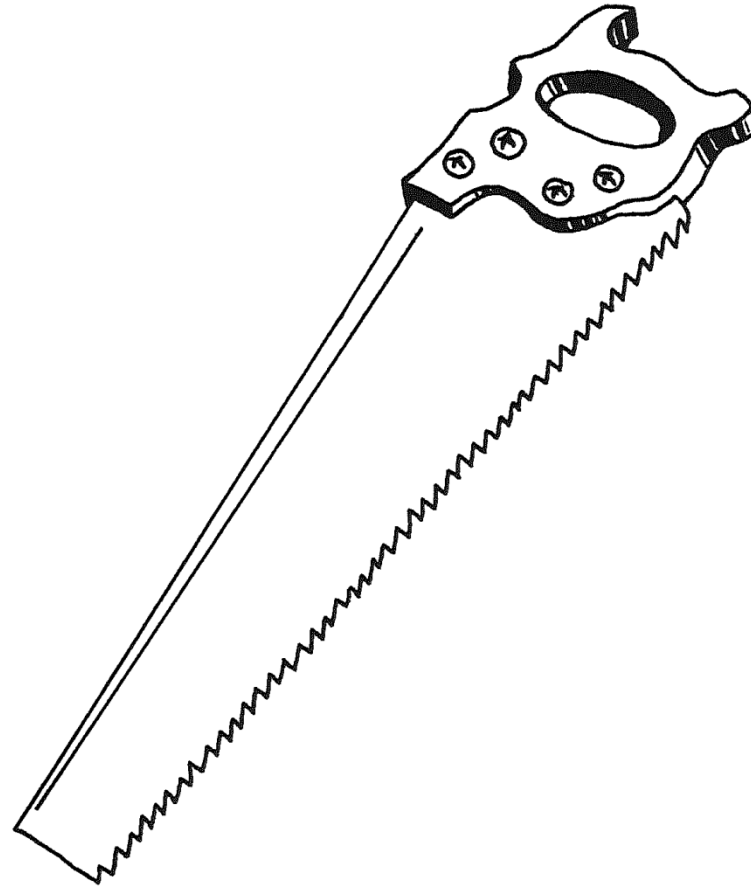

84B. visselpipa

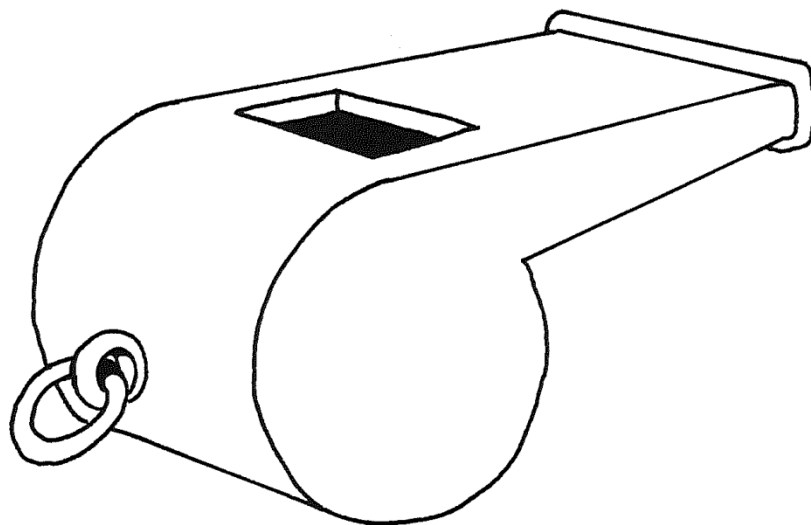

84C. trumma

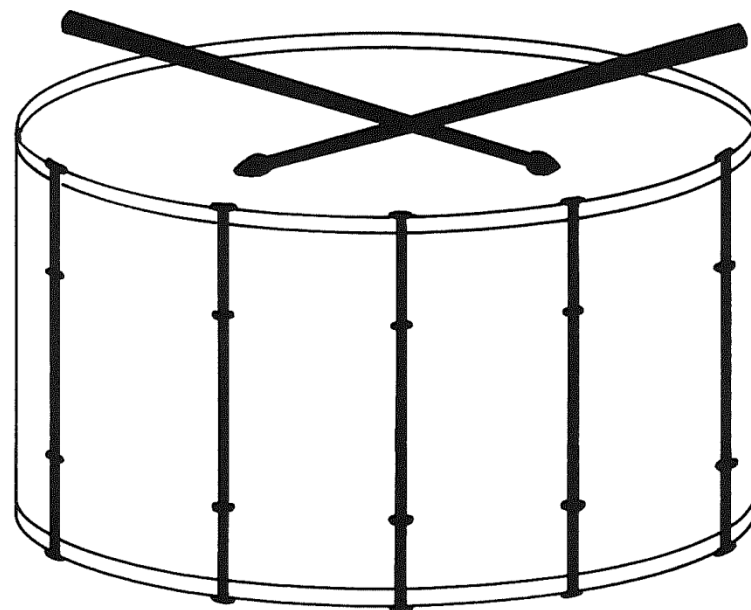

84D. boll

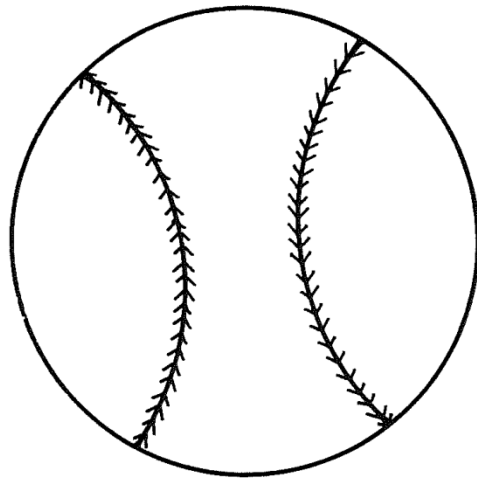

84E. nyckel

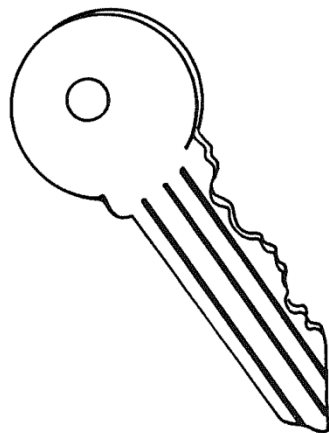

Observera: Båda uppgifterna kan göras samtidigt. Hela Uppgift 85 behöver inte göras innan Uppgift 86 görs.

85. Pekar på 14 av 20 bilder när de benämnas av testledare.

86. Benämner 14 av 20 bilder rätt. (Godtagbara svar finns inom parentes.)

85A. Peka på koppen.

86A. Vad är det här? (ko, mu-mu, kalv, tjur)

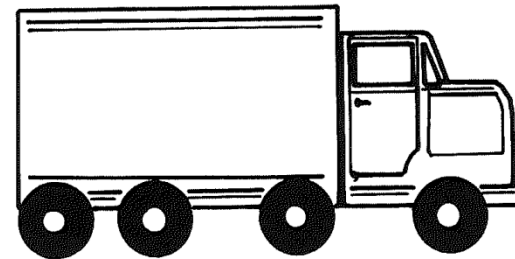
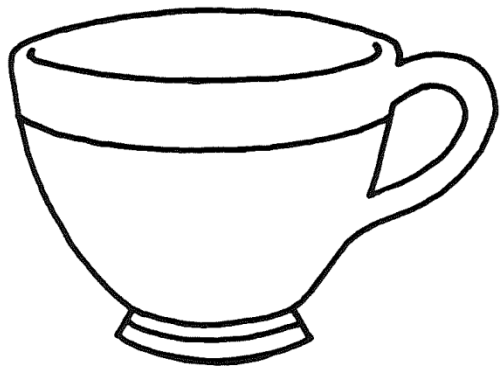
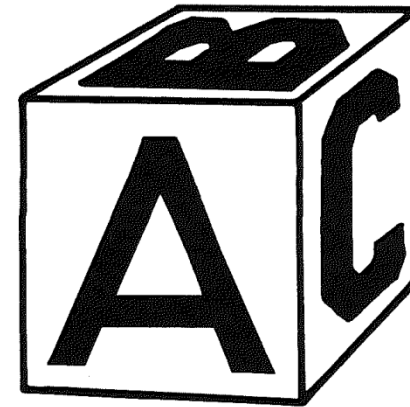
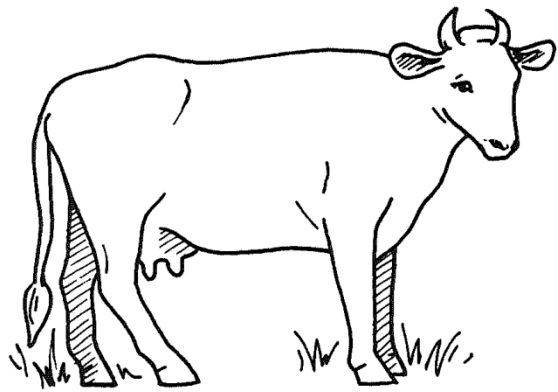

85B. Peka på babydockan.

86B. Vad är det här? (boll, någon slags boll – basketboll, tennisboll etc.)

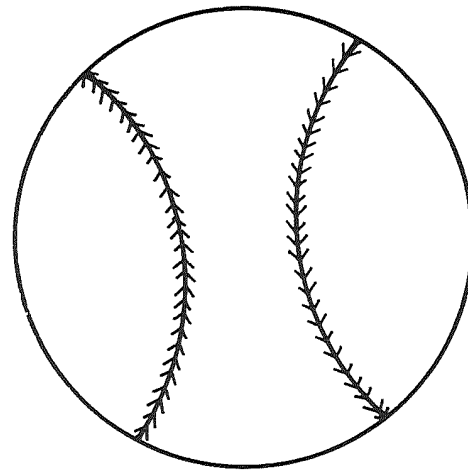
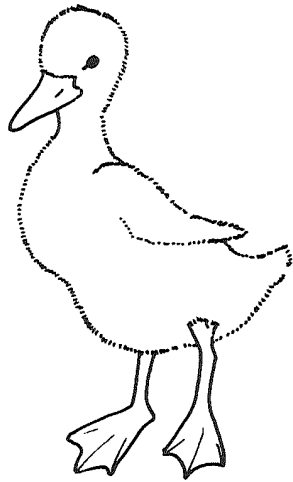

85C. Peka på nyckeln.

86C. Vad är det här? (blomma, ros etc.)

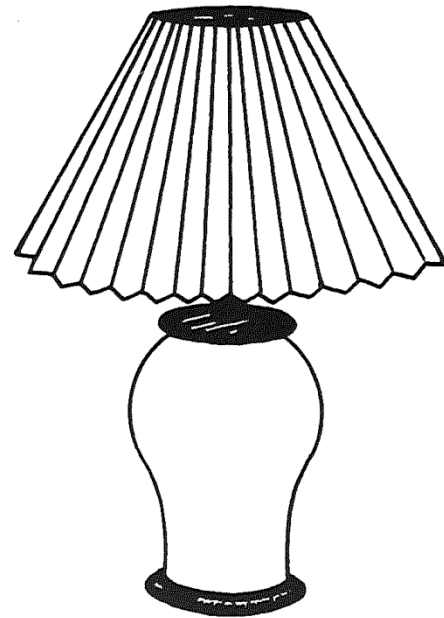
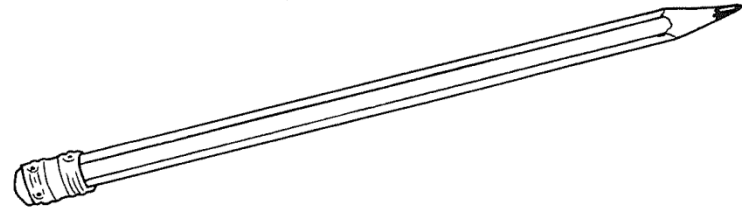
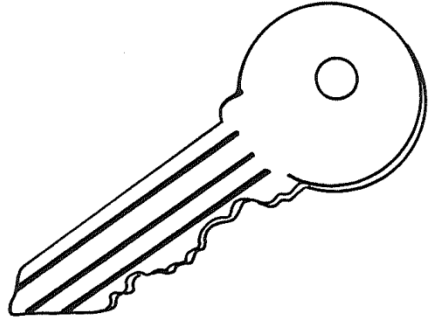

85D. Peka på flygplanet.

86D. Vad är det här? (barnvagn, sittvagn, kärra eller meningar som beskriver en barnvagn – något att köra ett barn i, vagn med barn i etc.)

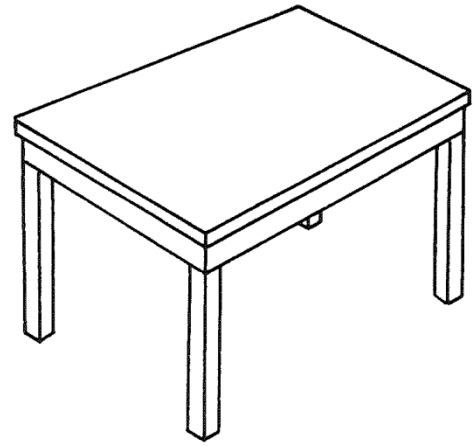
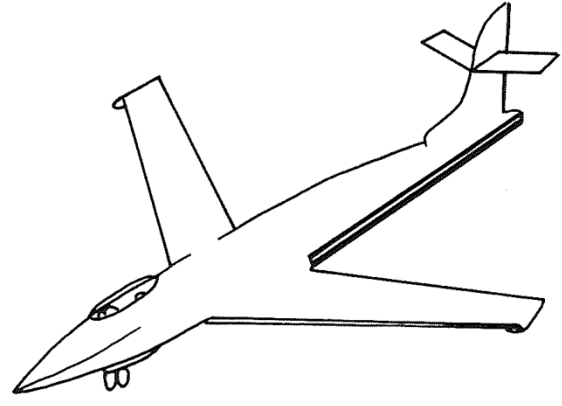

85E. Peka på buren.

86E. Vad är det här? (tandborste, borste)

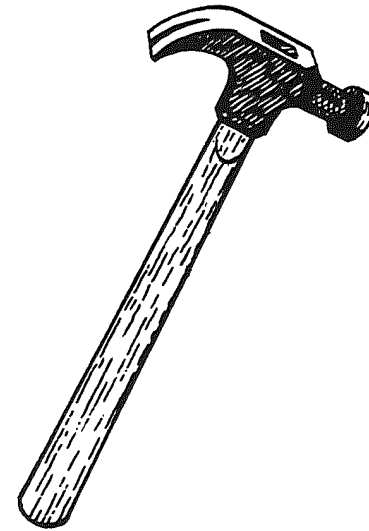
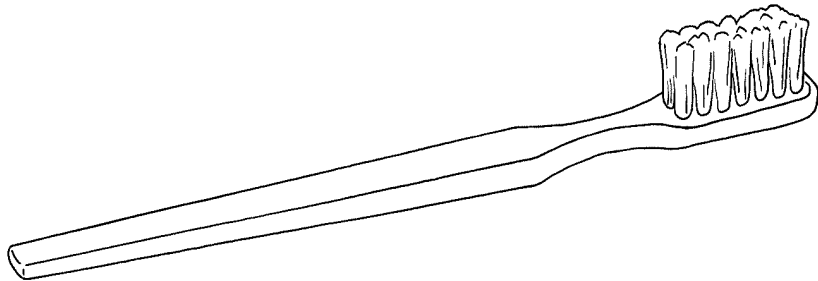

85F. Peka på paraplyet.

86F. Vad är det här? (kylskåp, frysbox, frys etc.)

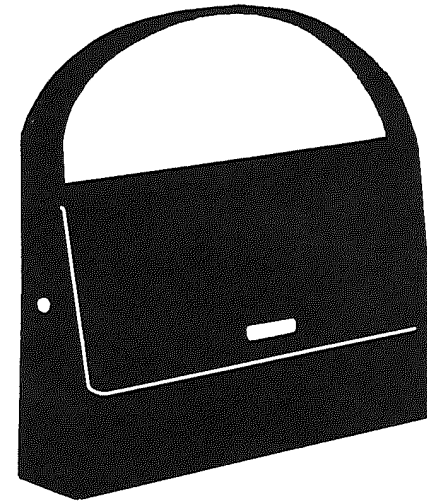
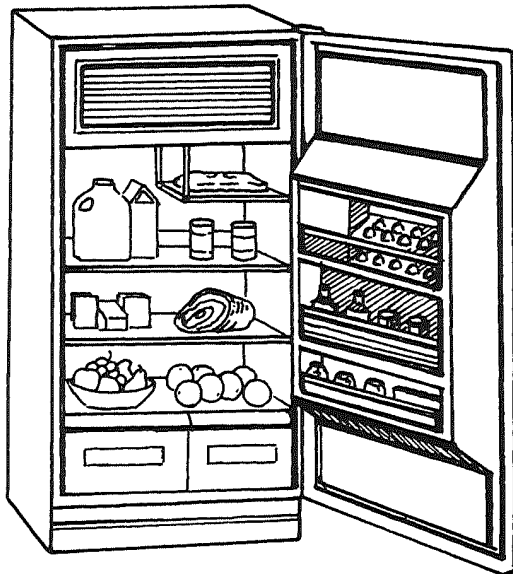
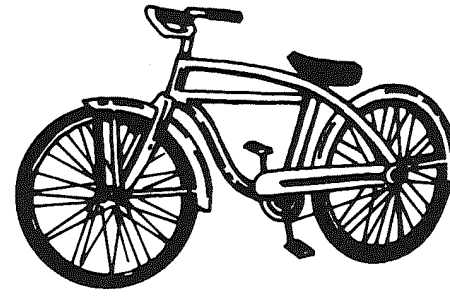

85G. Peka på lagar mat.

86G. Vad gör hon? (målar)

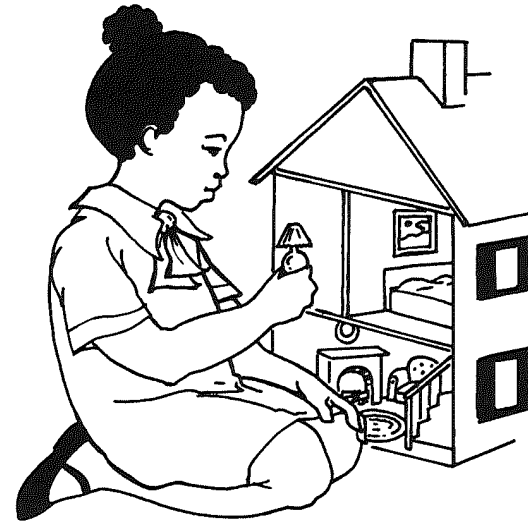
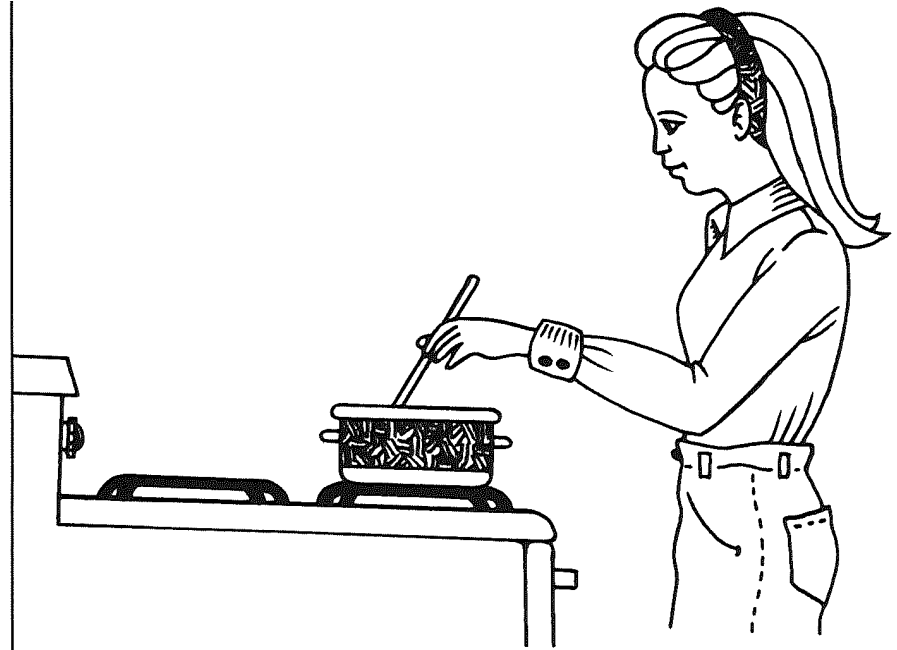

85H. Peka på knyter.

86H. Vad gör han? (gungar)



851. Peka på staketet.

861. Vad är det här? (flaska, Coca-Cola, tom flaska etc.)

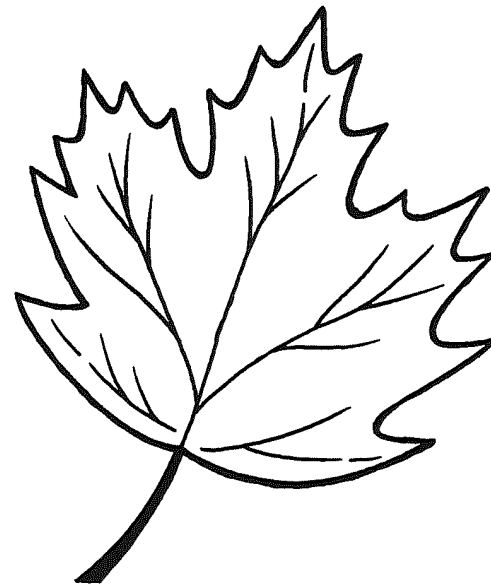
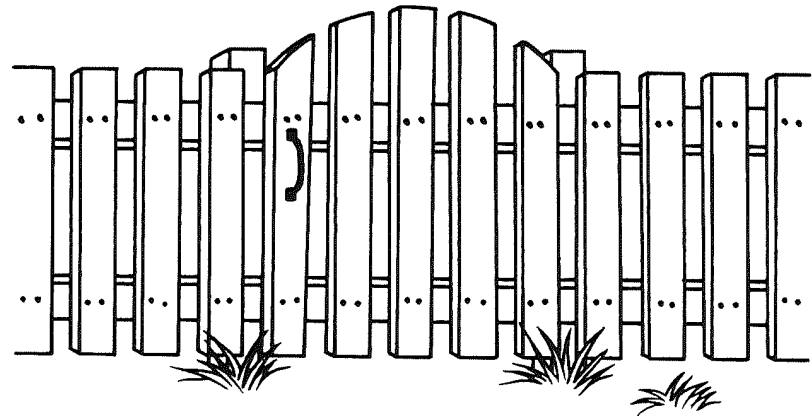

85J. Peka på handdockan.

86J. Vad är det här? (fläkt)

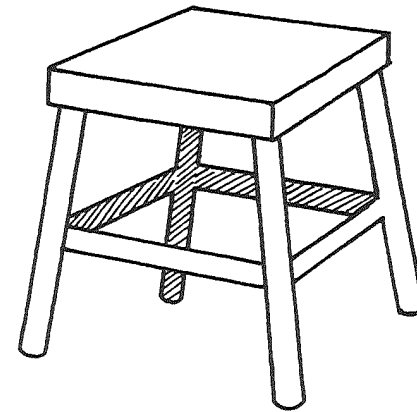
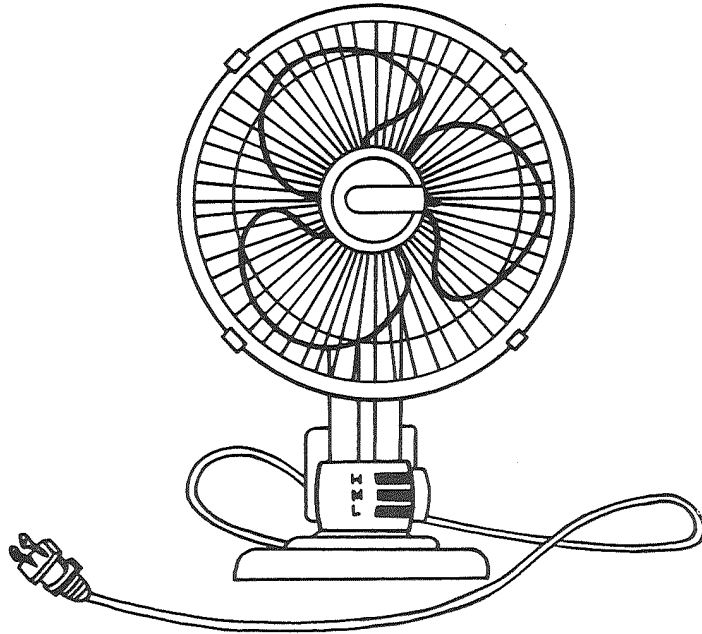
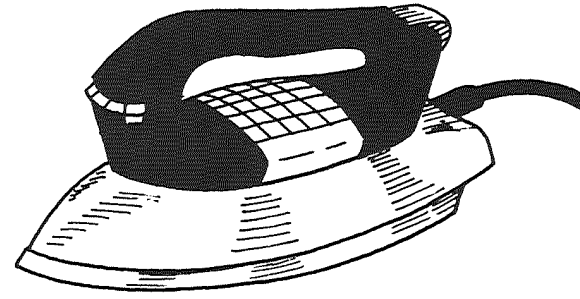
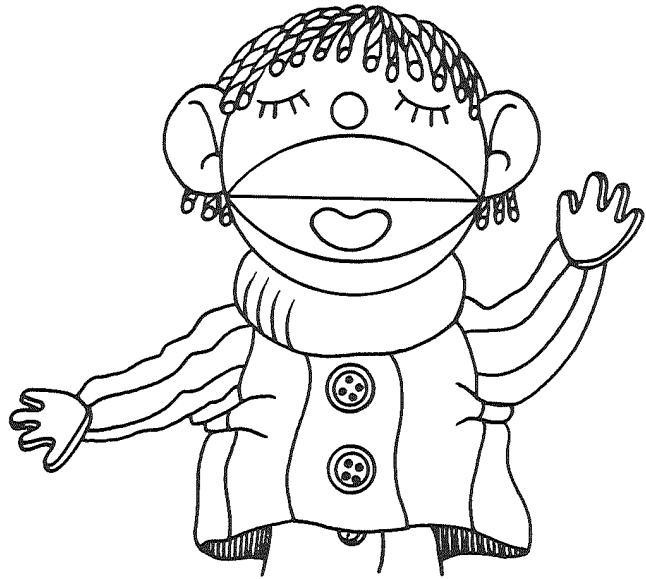

85K. Peka på kalkonen.

86K. Vad är det här? (känguru)

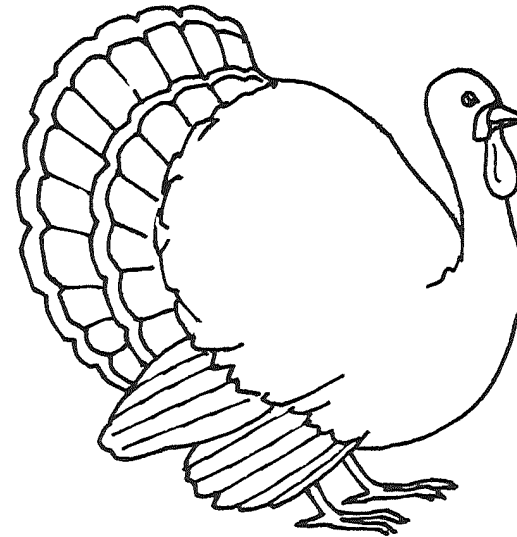
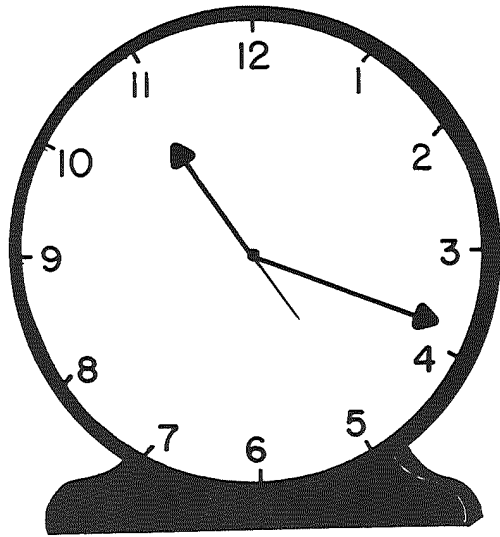
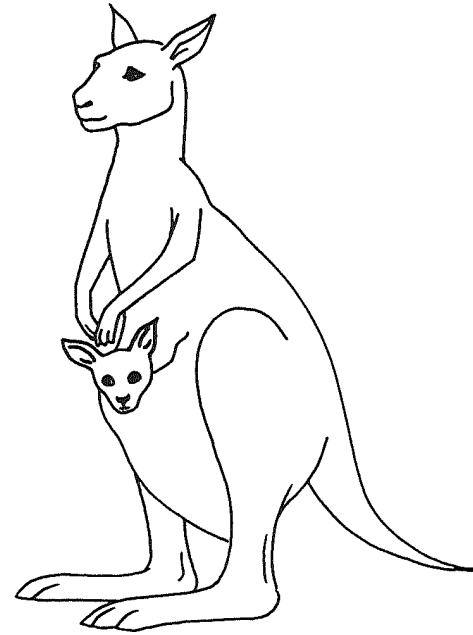
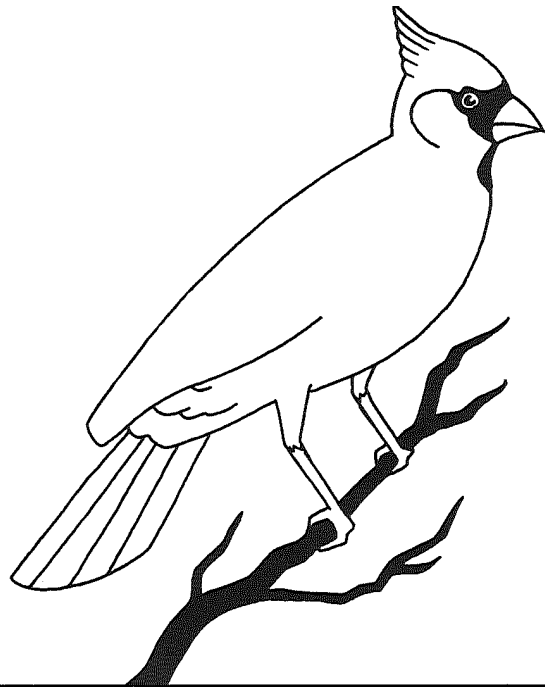

85L. Peka på fångar.

86L. Vad gör hon? (åker skridskor, åker rullskridskor)

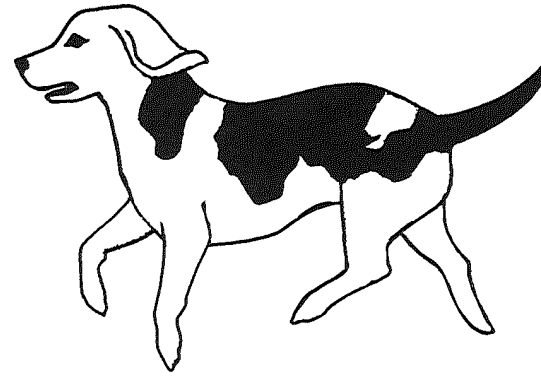

85M. Peka på bygger:

86M. Vad gör han? (bär, håller, leker, går med hunden etc.)

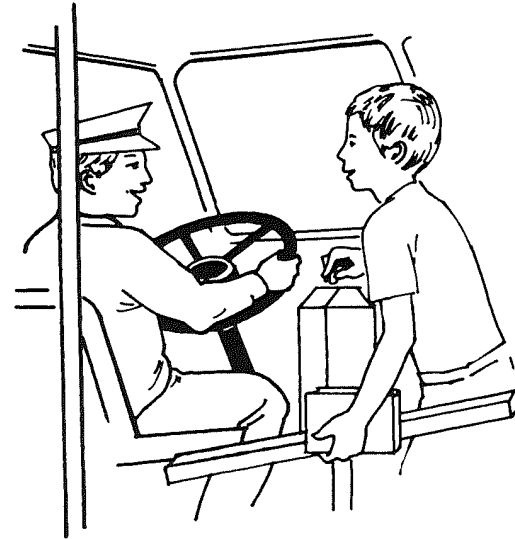
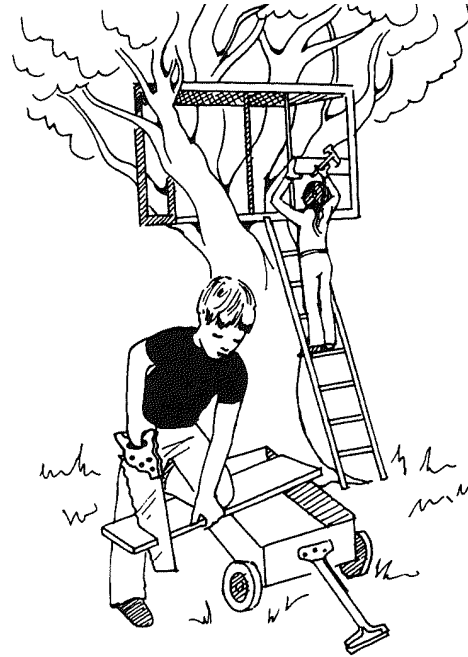
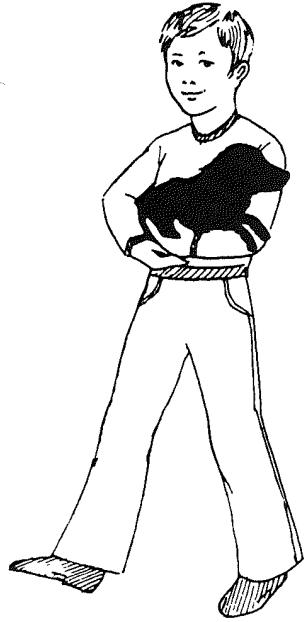

85N. Peka på polisen.

86N. Vad är det här? (doktor, sjuksköterska)

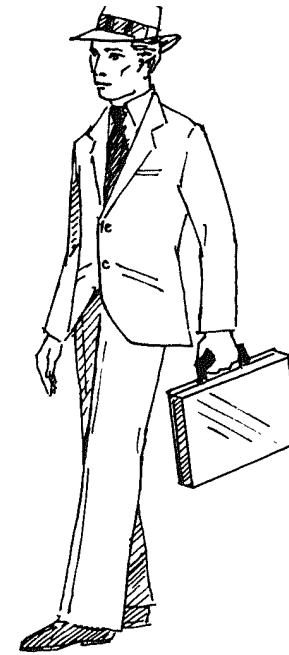

850. Peka på staplar.

860. Vad gör hon? (dyker, simmar, hoppar i vattnet, hoppar i, ska simma etc.)

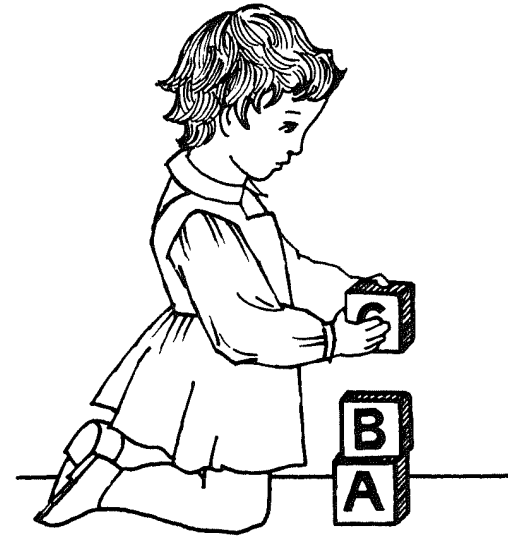
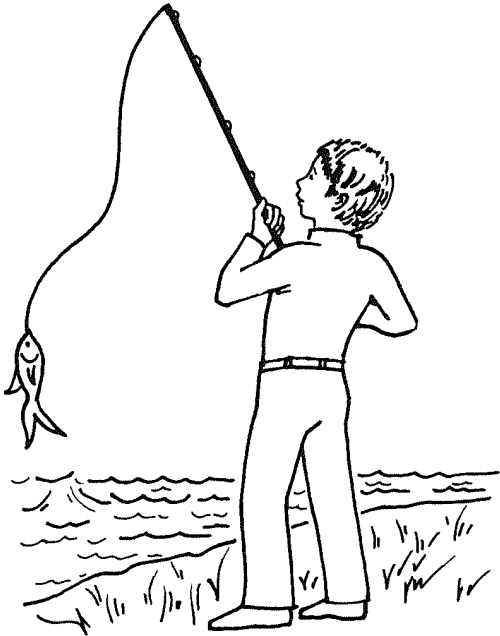
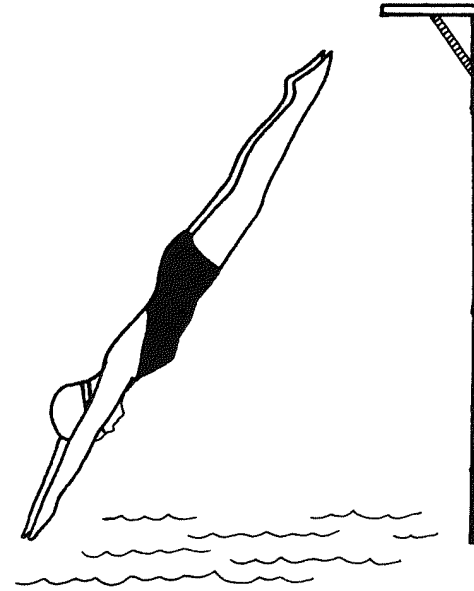
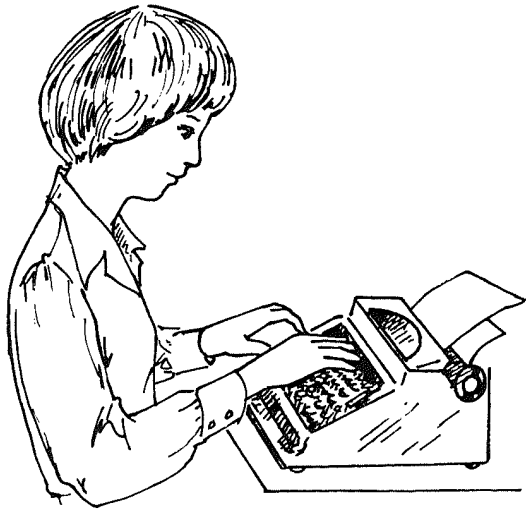

85P. Peka på plöckar.

86P. Vad gör de? (åker, sitter i vagnen, får skjuts, är ute och åker etc.)

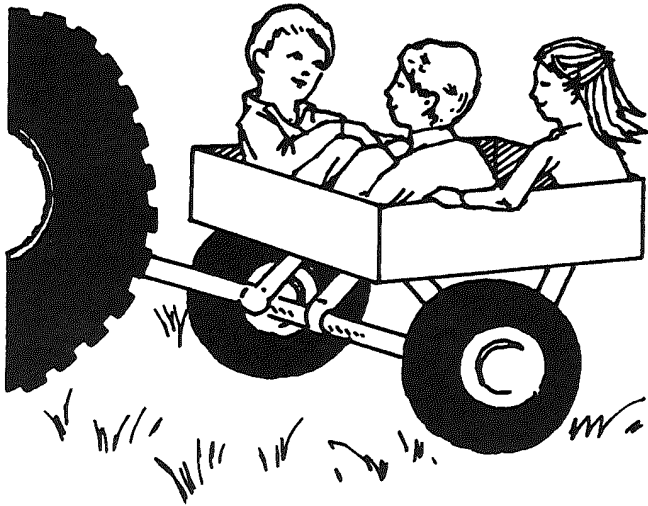
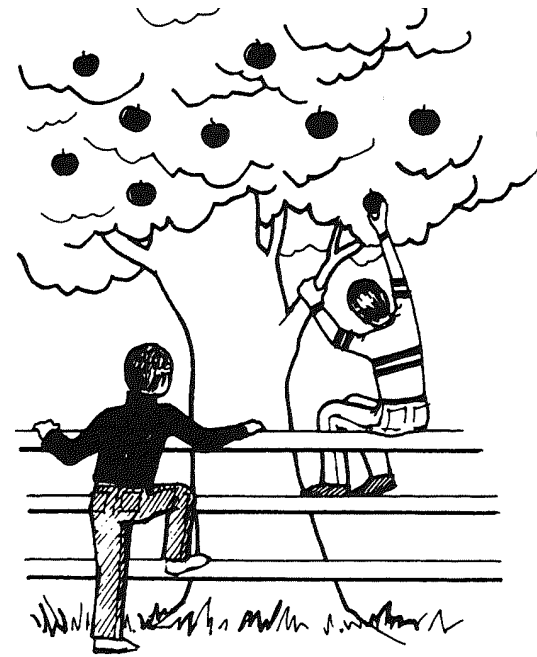

85Q. Peka på badar.

85Q. Vad gör han? (lyfter, tränar muskler, motionerar, plockar upp, håller upp etc.)



85R. Peka på termosen.

86R. Vad är det här? (kyrktorn, kyrka, tempel, torn, klockhus etc.)

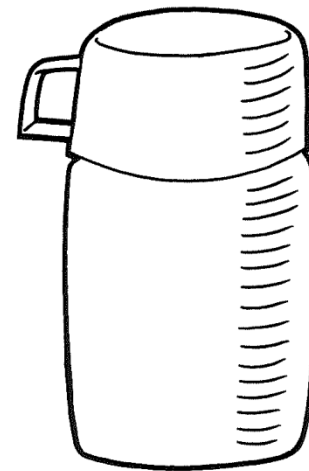
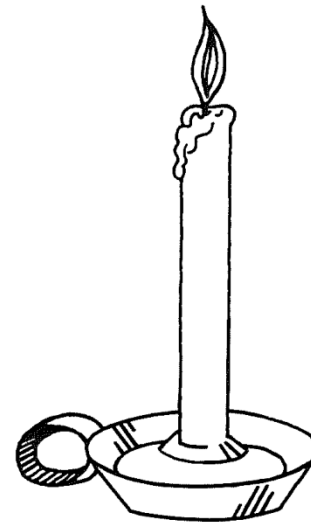
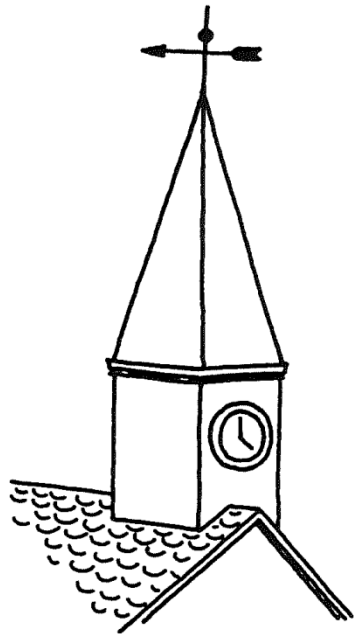

855. Peka på loket.

865. Vad är det här? (täjt)

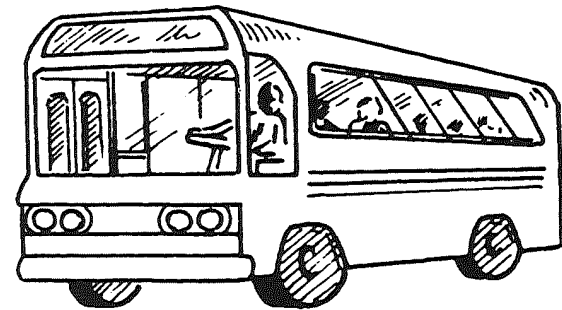
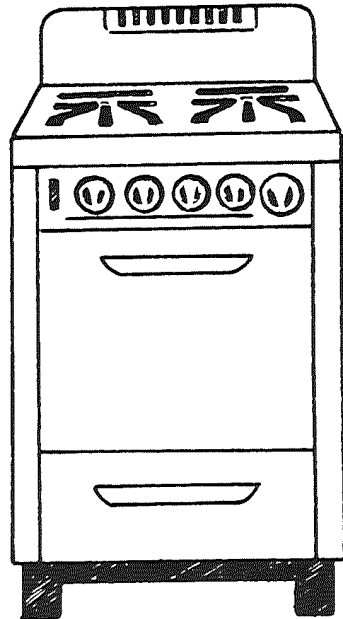
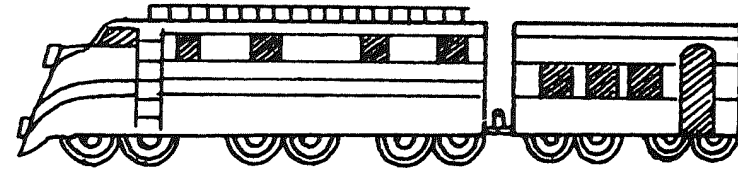
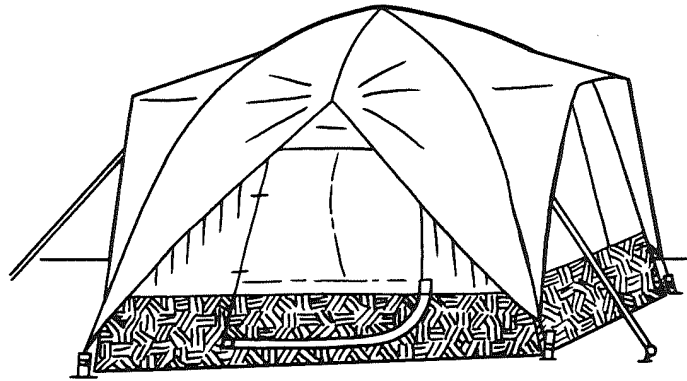

85T. Peka på uppskjutning.

86T. Vad gör han? (kör grävsropa, skyfflar jord, gör en väg, arbetar, bygger, kör bort snö, kör lastbil etc.)

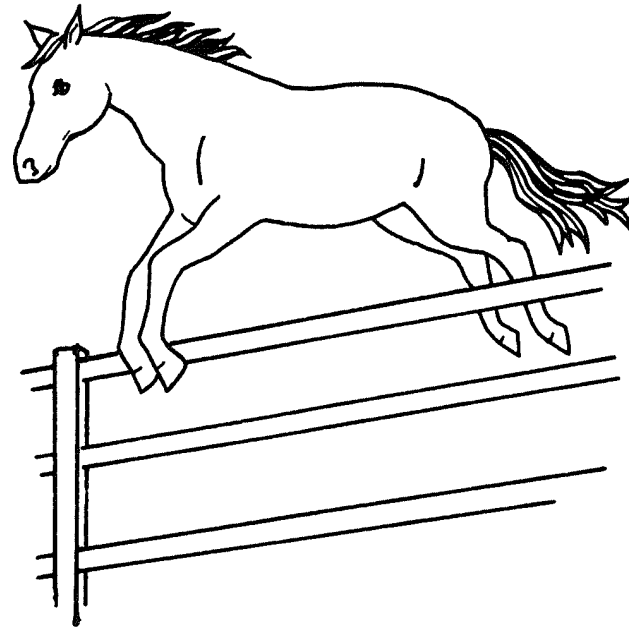
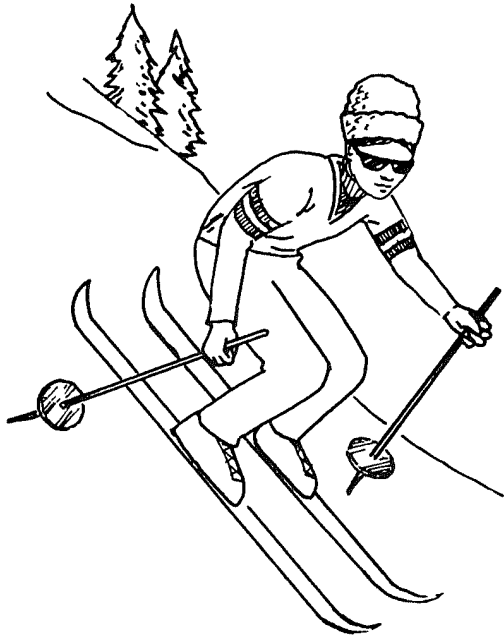
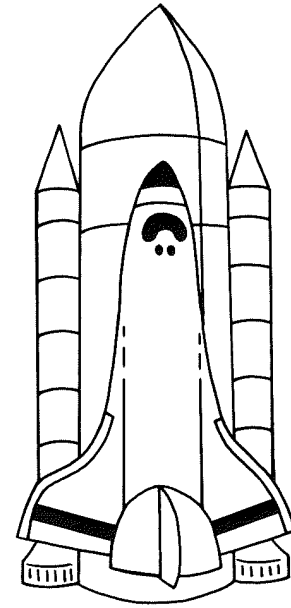
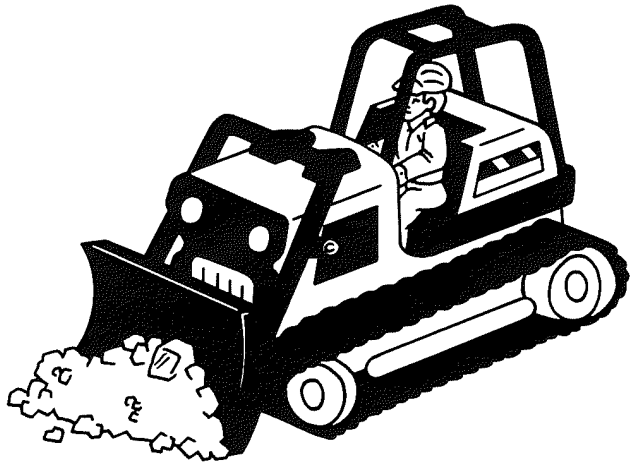

H

J

V

Z

U

E

Y

S

G

3 1 8 4 10

7 2 6 9 5

- 92. Läser 3 ord.
- 93. Läser 1 kort mening rätt.
- 94. Läser stycke utan att göra mer än 3 fel.
- 95. Läser stycke och svarar på 2 förståelsefrågor rätt.
- 96. Läser mening i stycke och följer instruktioner.

Boll

Hund

Katt

Hus

Tommy har en hund och en katt.

Tommy har en stor boll också.

Hunden, katten och Tommy bor i ett hus.

Tommy tycker om att leka med sin katt och hund.

Hunden hoppade på Tommys boll och sprang nerför gatan.

Tommy fångade hunden. De gick hem.

Tommy tog bollen och la den i lådan.

105. Matchar 5 färgade klossar med 5 färgade cirklar.

